

# ANKER-3 ASSEMBLY GUIDE

VERSION: ANKER-3-001-150LB/200LB/225LB

PART #: 5777301-E



**TORQUE** USA

# TABLE OF CONTENTS

## Important safety instructions:

- Important safety instructions for using equipment: **Page 3**
- Important safety instructions for assembling equipment: **Page 3**
- Obtaining service: **Page 3**

## General Notes:

- Unpacking equipment: **Page 4**
- Tools Required: **Page 4**
- Optional equipment: **Page 4**
- Assembly tips: **Page 4**

**Parts List: Page 5**

**Part Diagram: Page 6**

**Assembly Instructions: Pages 7 - 20**

**Optional attachments: Page 21**

## Adjustments and Maintenance:

- Cable adjustments: **Page 19**
- Maintenance: **Page 22**

**Decals and Warning Labels: Page 23**

**Live Area: Page 24**

**Dimensions: Page 25**

**Exercise Instructions: Page 26**

**Resistance Ratio Chart: Page 27 & 28**

# WARNING !

## Important safety instructions for using Equipment

There is a risk assumed by the individuals who use this type of equipment. To minimize risk, you must follow these precautions:

1. **READ ALL INSTRUCTIONS AND WARNING LABELS COMPLETELY PRIOR TO ANY USE OR ASSEMBLY.** Failure to read and follow the safety instructions and warnings within the Assembly and Maintenance Guide may result in possible serious injury or death. Use this product only for the intended uses described in the Assembly and Maintenance Guide and exercise booklet. **DO NOT** modify equipment in anyway. **Any use other than as intended or modification of product will void any and all product warranties.**
2. Consult your physician before starting any exercise program. Warm up properly before engaging in resistance training. Stop exercising and consult a physician immediately if you experience dizziness, nausea, faintness, chest pain, shortness of breath or any other abnormal symptoms during use of this equipment.
3. Certain exercise equipment and/or equipment may not be suitable or appropriate for pregnant women, people with heart conditions, balance impairment or other pre-existing health problems. Persons with disabilities should consult a physician and obtain medical approval prior to using this product and should only use this product under close supervision. **Failure to comply with these instructions will void any and all product warranties.**
4. Carefully inspect equipment before each use. Replace all parts at the first sign of wear or damage. Tighten all loose connections. Pay special attention to cable ends and connections. Do not disassemble, remove any parts or components or otherwise attempt to repair this product. **DO NOT** use product if product appears damaged. **DO NOT** attempt to fix a broken or jammed machine, obtain assistance from your authorized Torque Fitness Dealer. **Failure to comply with these instructions will void any and all product warranties.**
5. Keep body and clothing clear of all moving parts. Do not put any foreign on or near this product when in use. Wear comfortable clothing which does not impair freedom of movement. Do not wear clothing which is too loose and could get caught in moving parts.
6. Make sure all adjustment spring pins are fully engaged after making an adjustment and before using the product.
7. Make sure weight stack selector pin is completely inserted into the weight stack before beginning any exercise.
8. Children and pets must not be allowed near this machine. Supervise teenagers. This product is not a toy. Owner must notify any user of all warnings and proper use of equipment.
9. This product is designed for Class H, home indoor use only. Unless directly specified, the maximum user weight is 300 lb (136 kg). If unsure of proper use of this product, contact Torque Fitness Customer service at: 763-754-7533 (8:30 am - 5:00 pm CST) or email [service@torquefitness.com](mailto:service@torquefitness.com)

## Important Safety Instructions for Assembling Equipment

1. **Assistance is required. Torque Fitness recommends using more than one person to assemble this equipment.**
2. This product must be assembled on a flat, level surface to assure its proper function. Locate the unit a few inches from walls or furniture to allow easy access during assembly and use.
3. Read each numbered step in Assembly and Maintenance Guide and follow the steps in sequence. Skipping ahead may result in damage to the equipment and may require components to be disassembled.
4. Wear proper attire during the assembly process. Do not wear clothing which is too loose or open toed shoes.

## Obtaining Service

Do not attempt to service the product yourself except for maintenance tasks described in this manual.

Refer to the Adjustments and Maintenance section at the back of this manual and the included workout booklet for information on product operation and service.

For further information, visit our website at [www.torquefitness.com](http://www.torquefitness.com) or contact us at [service@torquefitness.com](mailto:service@torquefitness.com)

If you call or email customer service, have the model number and serial number(s) available. The location of the model and serial numbers are indicated in the back of this manual. For future reference, write the model and serial number(s) in the space below.

Model Number: \_\_\_\_\_

Serial Number(s): \_\_\_\_\_

**Torque Fitness**  
11201 Xeon Street NW Suite 101  
Coon Rapids, MN USA 55448

# GENERAL NOTES

**CAUTION:** More than one person is required to assemble this unit. Do not attempt to assemble by yourself.

## Unpacking the Equipment

This product may be packaged and shipped in multiple boxes. Parts from all of the boxes are required for various steps during the assembly process.

Carefully open each box and arrange all the parts near the area where assembly is to take place.

**CAUTION:** Use extreme care when cutting plastic tie wraps and package banding. A wire cutter works best for protecting yourself and the parts.

**CAUTION:** Some of the internal boxes may contain upholstery. Do not use a utility knife to open any boxes or the pads may be damaged.

The hardware is packed in bags. Carefully open each bag and sort them per parts list on the next page.

Before starting assembly, identify each part and hardware item as listed in the parts list on the next page. If any items are missing, contact Torque Fitness Customer service at: 763-754-7533 (8:30 am - 5:00 pm CST). Email: [service@torquefitness.com](mailto:service@torquefitness.com)

**Note:** Some items listed in the parts list may already be pre-installed on the product.

## Tools Required

- Rubber mallet or hammer
- 3/4" Box wrench or adjustable wrench
- 9/16" Box wrench or adjustable wrench
- Ratchet with 9/16" socket
- 5/32", 3/16", 5/16" Allen wrench
- Wire snips (to cut plastic tie wraps)
- Scissors or utility knife (to cut hardware bags)
- Step stool or ladder
- Tape measure
- Level
- Power Drill
- 1/4" drill bit

## Optional Equipment

Optional equipment may be available for this product.

Follow the instructions included with the optional equipment to assemble it to the base product.

## Assembly Tips

- In a continual effort to improve our products, specifications are subject to change.
- A 6" scale is provided at the bottom of every page. To correctly measure the bolts, measure from underneath the bolt head to the end of the bolt as illustrated below.
- Read all notes on each page before beginning that step.
- Some of the items shown in the assembly steps may already be pre-assembled.

## Assembly Tips Continued

- **Note:** Some items have been hidden for assembly clarity.
- **Note:** Some pre-assembled parts may need to be temporarily removed in order to complete the step. Follow the instructions or damage to the product could occur.
- Some parts may have extra holes that will not be used. Use only the holes depicted in the instructions.
- Certain parts make reference to the right and left side of the machine. In order to determine the left and right side, stand with your back to the front of the machine.
- Provide ample space around the product for ease of assembly.
- **DO NOT** fully tighten any connections until instructed to do so. This will help insure that the alignment of all of the parts will be correct.
- Insert all bolts in the direction indicated in the instructions. Failure to do so may result in clearance issues and will degrade the aesthetics of the product.
- Carefully follow instructions for all pivot points. In general, primary rotating parts have connections that should be securely tightened, while secondary connections need to be loosen 1/4 turn.

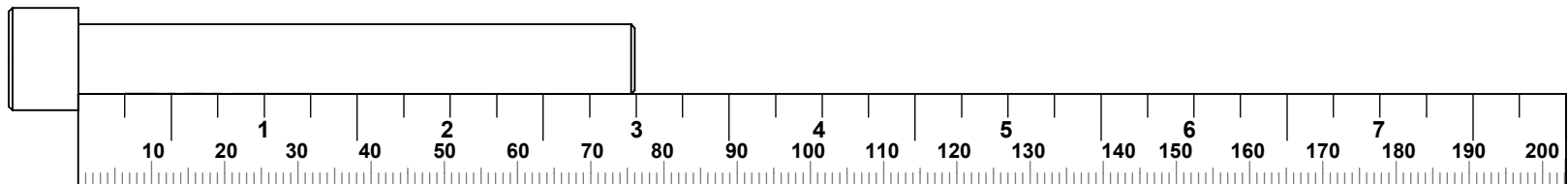

ITEM NO.	PART NUMBER	DESCRIPTION	QTY.
1	57721PA	PTD ASSY, LOWER FRAME	1
2	57734PA	PTD ASSY, UPPER FRAME	1
3	57740PA	PTD ASSY, SIDE FRAME	1
4	57776PA	PTD ASSY, SIDE FRAME	1
5	5513601	CUSHION, WEIGHT STACK	2
6	5774301	GUIDE ROD, 19 OD X 1953	2
7	5992401	SHAFT COLLAR, TWO-PIECE CLAMPING	2
8	5773901	CABLE ASSY, ANKER 3, LONG	1
9	5773101	CABLE ASSY, ANKER 3, SHORT	2
10	6065101	HOUSING, CABLE COUPLER	4
11	5509001	CORE, CABLE COUPLER	4
12	2003201	CAP SCREW, M5 X 0.8 X 6MM SOCKET HEAD	8
13	5745001	PTD ASSY, DUAL FLTG PULY	2
14	54970PA	PTD ASSY, HEAD PLATE PULLEY	1
15	55181PA	PTD ASSY, WEIGHT SELECTOR STORAGE PLATE	1
16	2001101	WASHER, FLAT 3/8 SAE ST ZN	8
17	2031101	SCREW, 3/8" LAG X 2.5"L CLEAR ZINC	8

ITEM NO.	PART NUMBER	DESCRIPTION	QTY.
18	2002601	NUT, 1/2 JAM ST ZN	1
19	2009402	BOLT, 3/8-16 X 3/4" (19mm) ST HT SOCKET HEAD W/NP	2
20	5666401	ASSY, WEIGHT STACK PIN	1
21	5091801	SNAP HOOK, 8MM DIA X 80MM	4
22	5784201	ASSY, LEG BOOT, SHORT	1
23	5324701	ASSY, SHORT STRAP HANDLE	2
24	5774201	ASSY, LONG STRAIGHT STRAP HANDLE	2
25	5794501	ASSY, PHONE HOLDER, 1.5 DIA TUBE	1
26	5790901	STRAP, BATTLE ROPE LOOP	1
27	5500701	LABEL, WEIGHT STACK 1-20	1
28	57097PA	PTD ASSY, HEAD PLATE	1
29	57094PA	PTD ASSY, 10 LB WEIGHT PLATE	SEE NOTE
30	57388PA	PTD ASSY, 15 LB WEIGHT PLATE	SEE NOTE
31	ANKER-PUA-101	PULL-UP ATTACHMENT - ANKER STRENGTH TRAINER	1

**NOTE:**

The ANKER 3 has three weight stack options. 150 LBS, 200 LBS, and 225LBS.

- The 150 LB. stack has fourteen 10 LB. plates and a head plate.
- The 200 LB. stack has ten 15 LB. plates, four 10 LB. plates and a head plate.
- The 225 LB. stack has fourteen 15 LB. plates and a head plate.

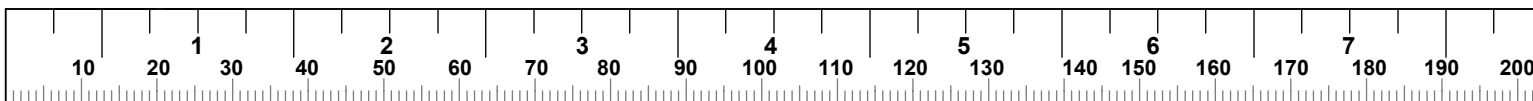

# PART DIAGRAM

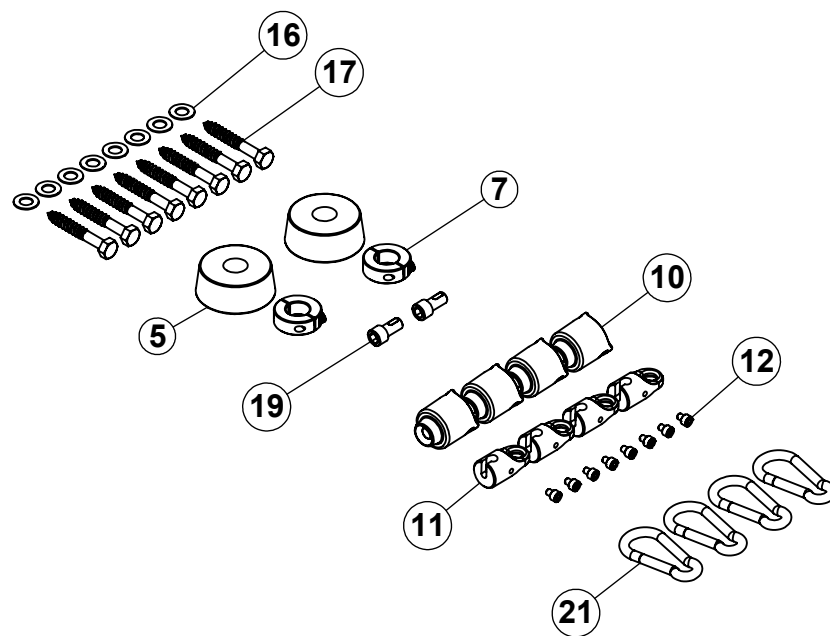
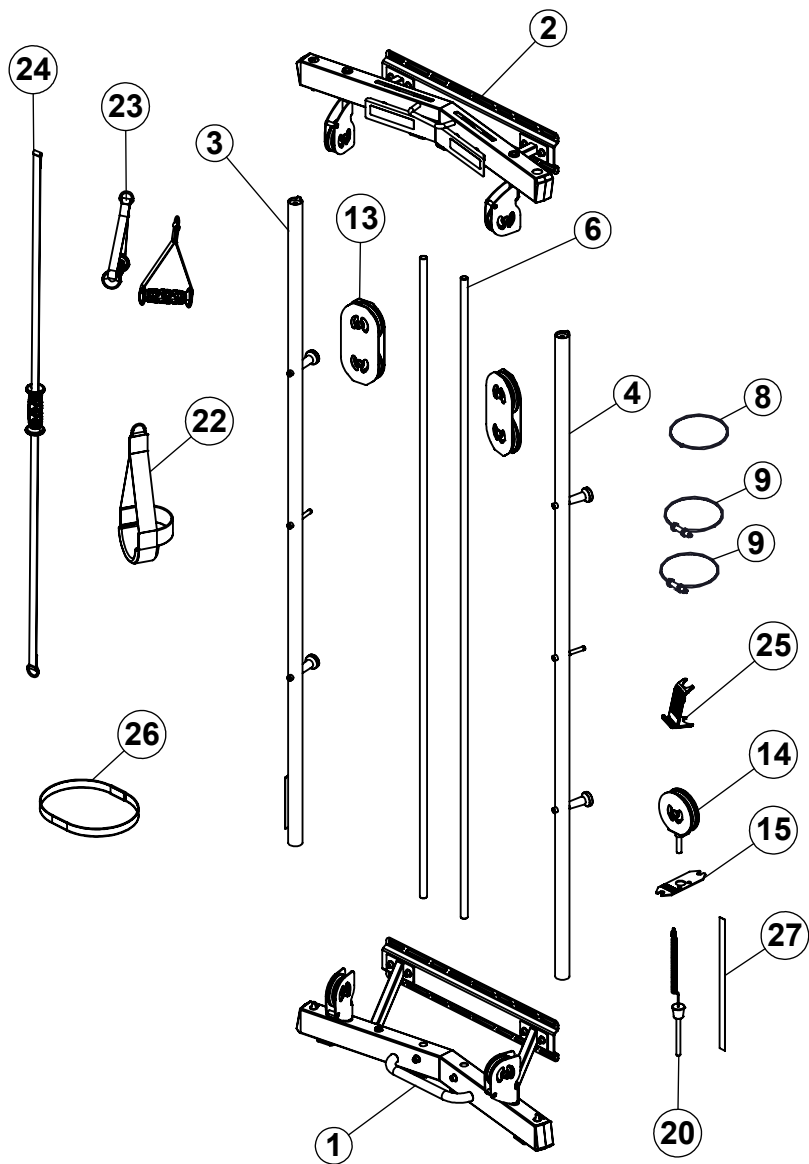

# STEP 1

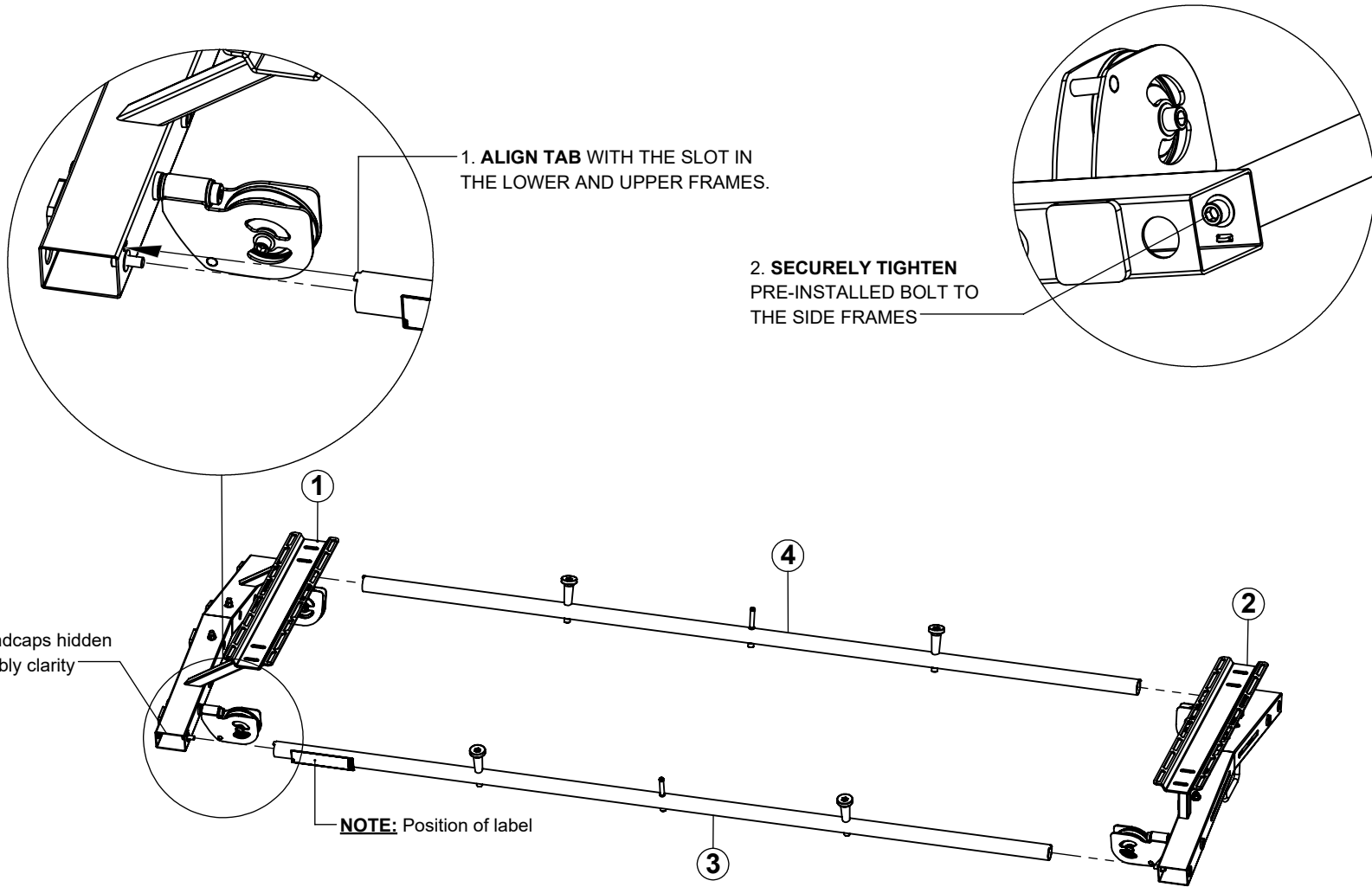

**SECURELY TIGHTEN** bolt connections in this step.

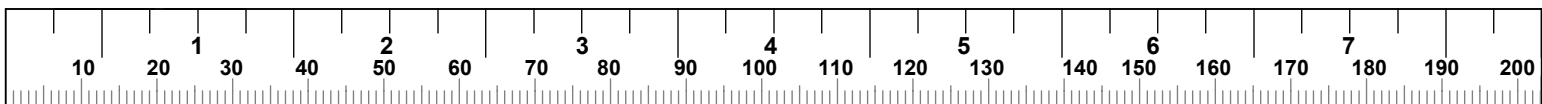

## STEP 2

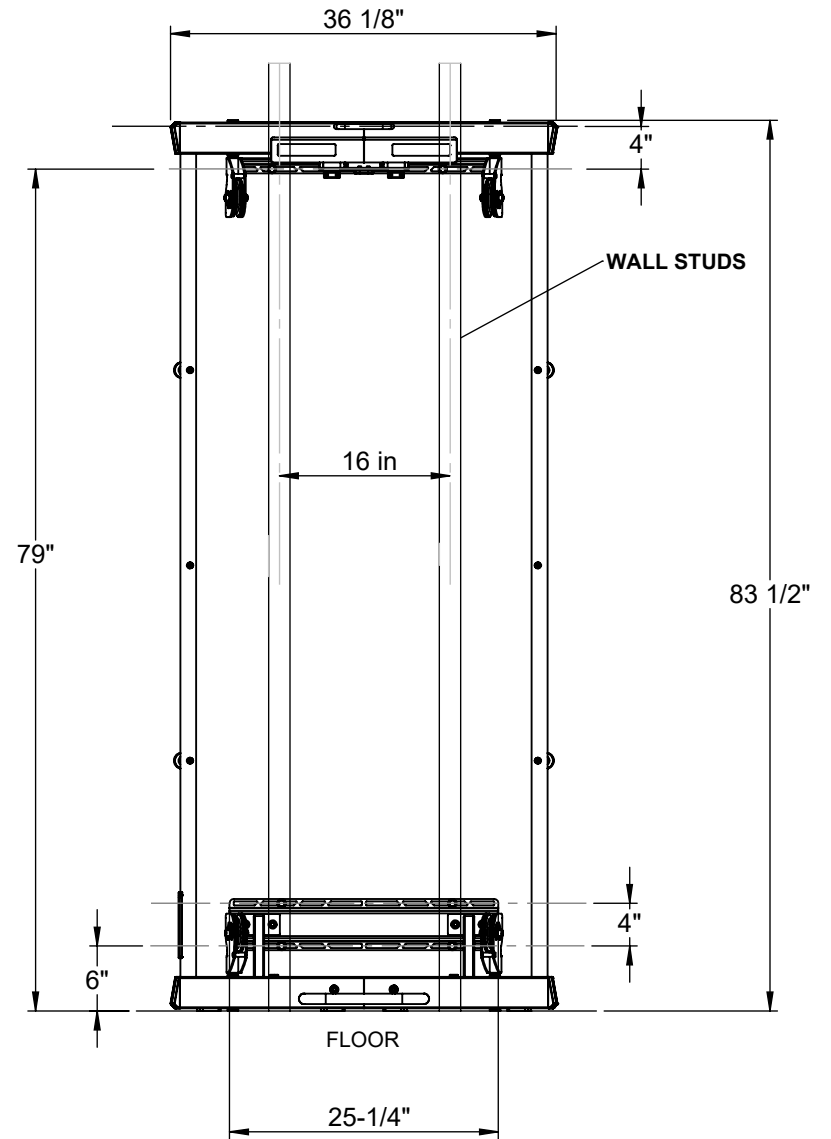
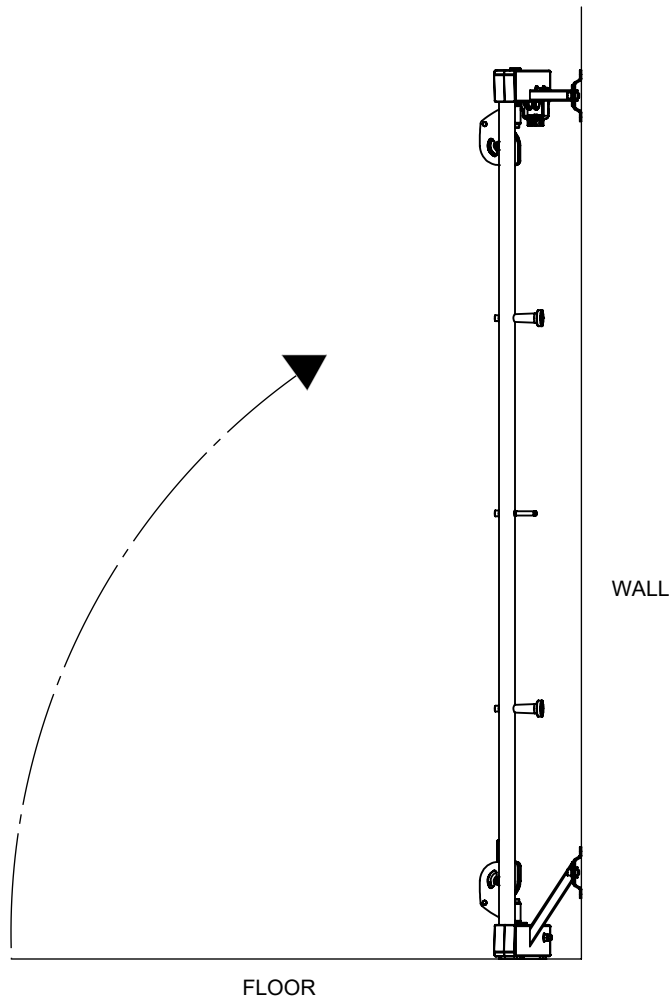

### NOTES:

Locate studs and desired location for mounting.

**Carefully** tip the unit up to the wall in desired location. Align slots with the studs and mark drilling locations. Pre-drill holes as needed for anchoring.

**ANKER-3** is shown being mounted to a typical wall with wood studs 16" on center. For 24" wall studs follow the same steps as shown.

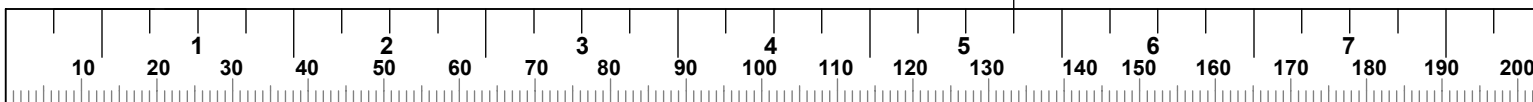

### STEP 3

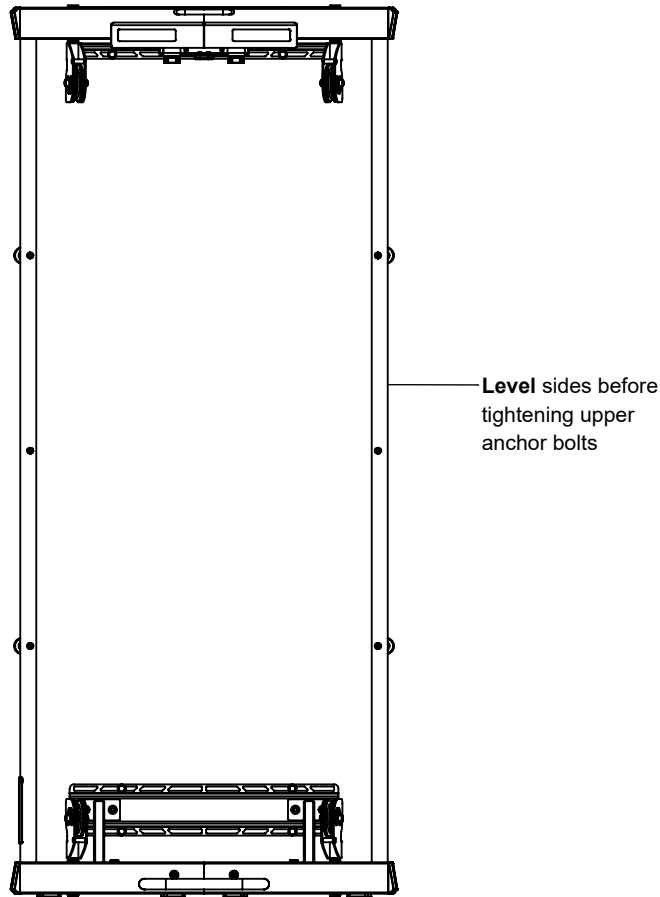

#### NOTES:

The image above shows how to attach the gym to the wall using wall anchors to a typical wood stud wall. The wall anchors used will depend on the wall construction. The pull-out strength of the anchoring hardware used must be equal to or greater than 200 lbs. (91 kg) each.

**NOTE:** Eight or more anchoring locations must be used.

**SECURELY** tighten all bolt connections in this step.

## **WARNING:**

THE ANKER-3 **MUST** BE ANCHORED TO THE WALL USING EIGHT OR MORE WALL ANCHORS SUITABLE FOR THAT PARTICULAR WALL CONSTRUCTION.

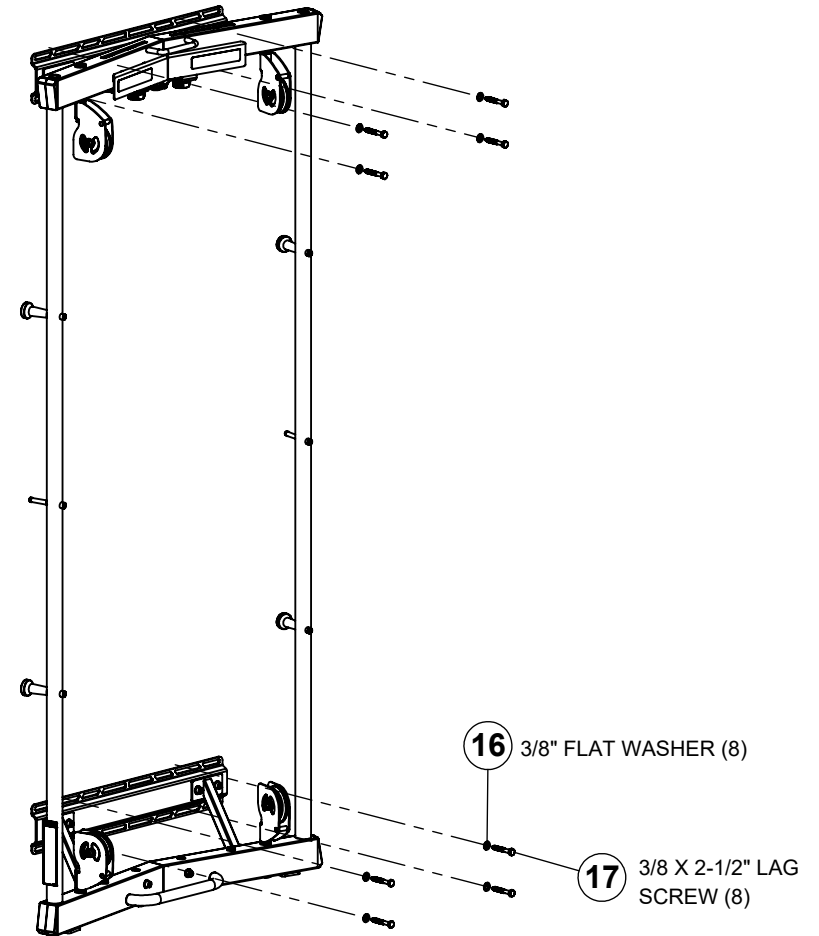

**NOTE:** Power tools may be used for installation of anchoring hardware. However, installing the top frame hardware may require using a ratchet wrench where frame clearance does not allow for drill or impact driver use.

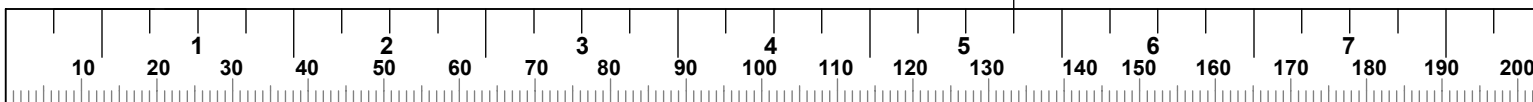

## STEP 4

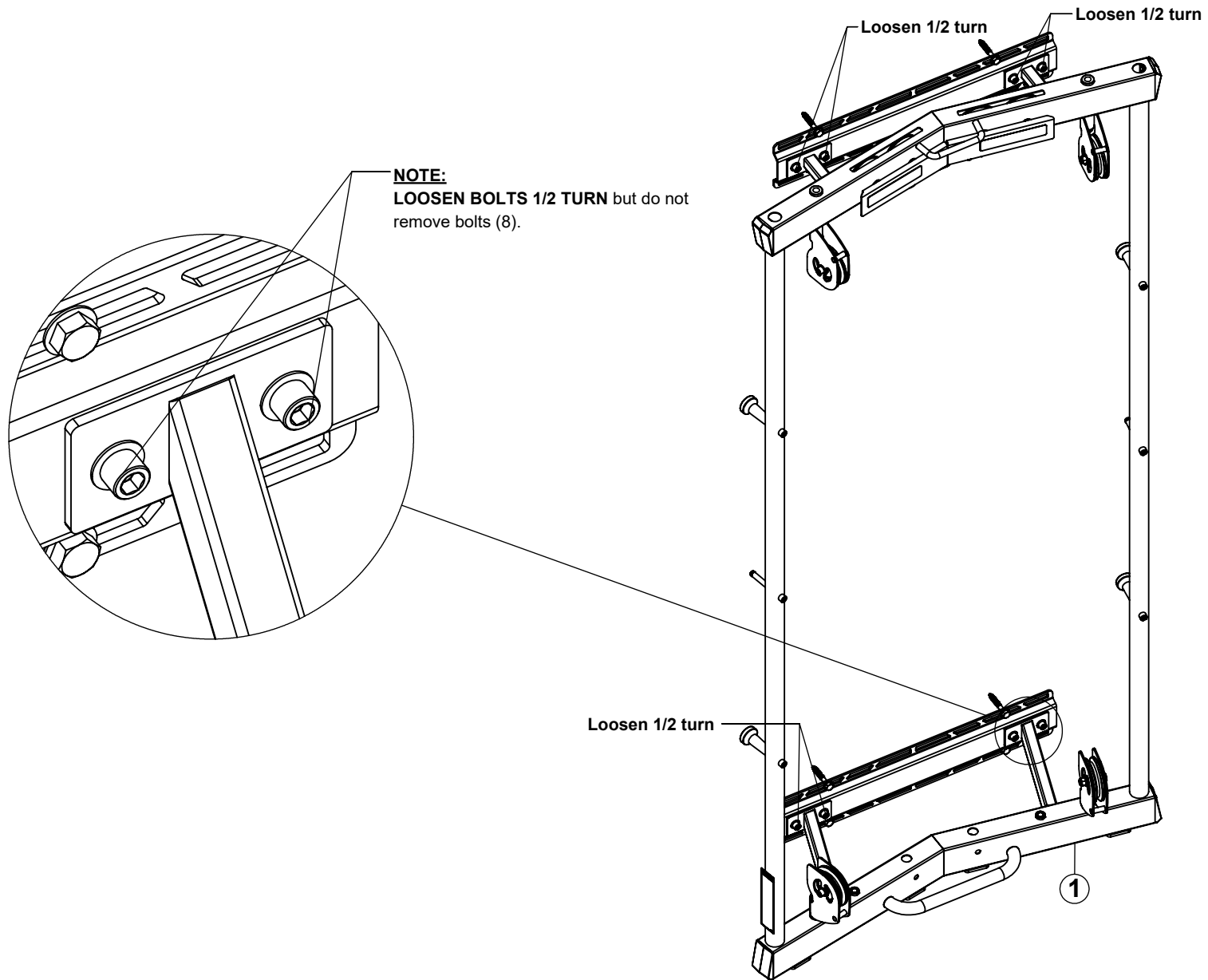

### **NOTES:**

Loosen bolts to prevent damage to wall when loading plates. Carpet and other soft surfaced flooring may cause movement of the frame when loading weight plates.

# STEP 5

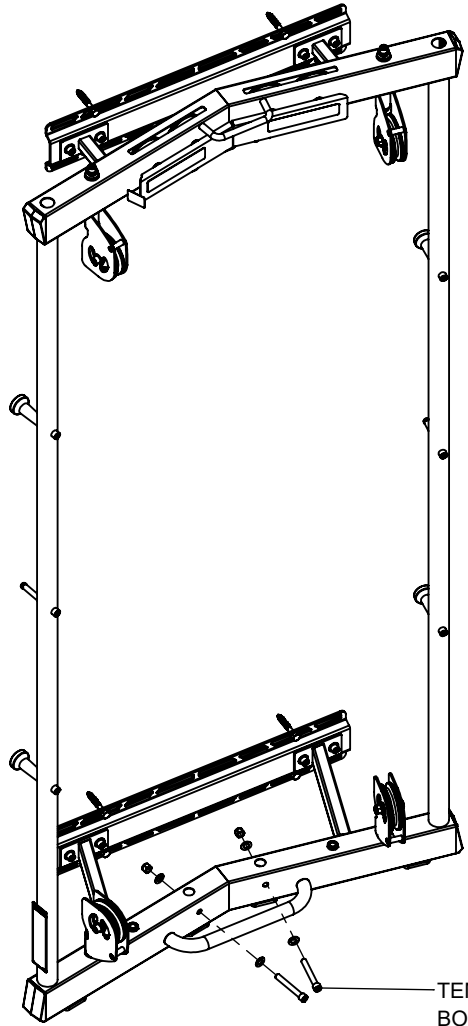

TEMPORARILY REMOVE  
BOLTS, WASHERS, AND NUTS

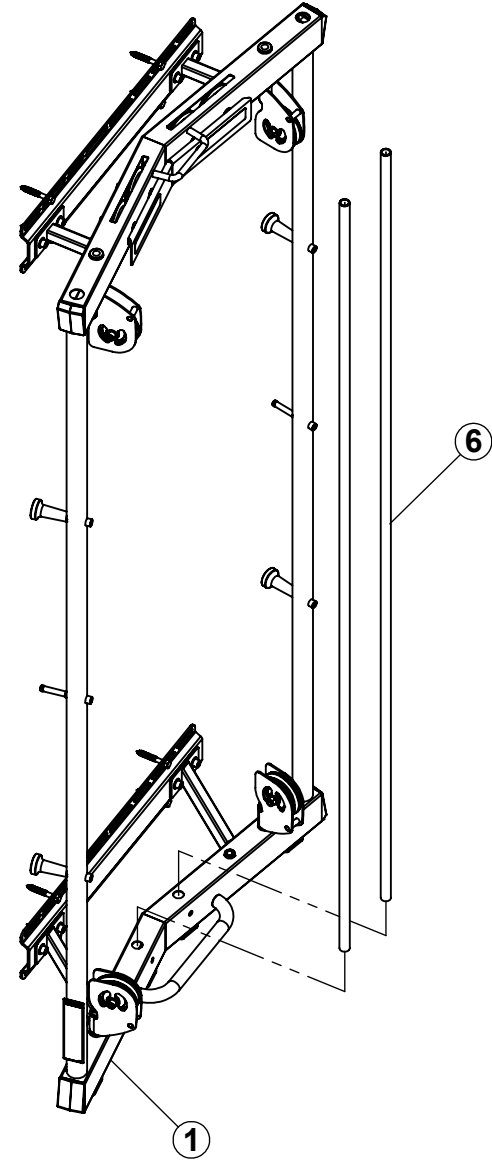

# STEP 6

3) Add headplate and lock collars. Allow lock collars rest on top of headplate. Do not tighten in this step

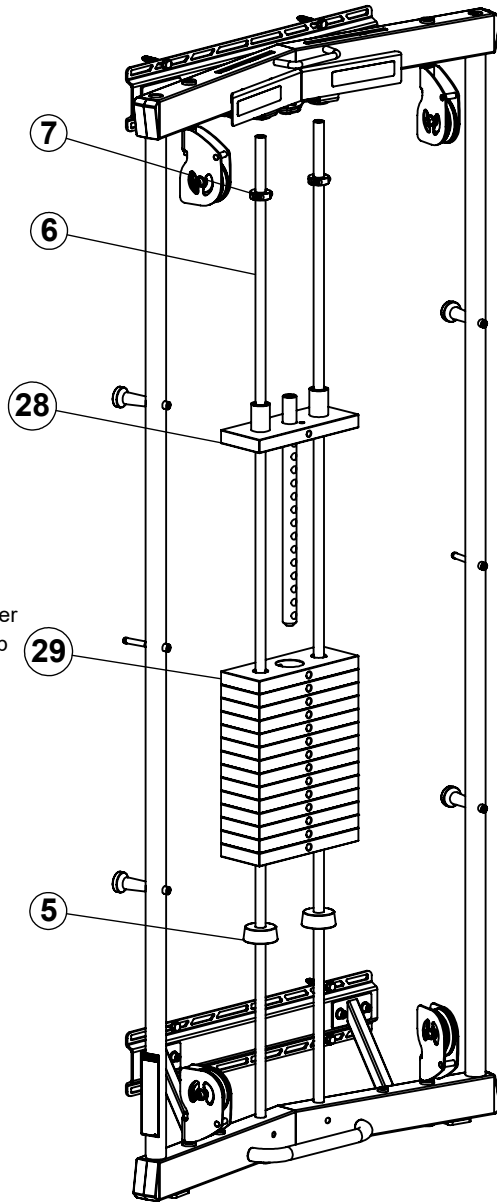

150 LB OPTION

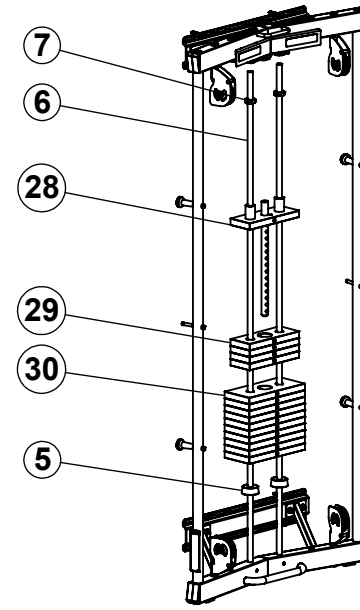

200 LB OPTION

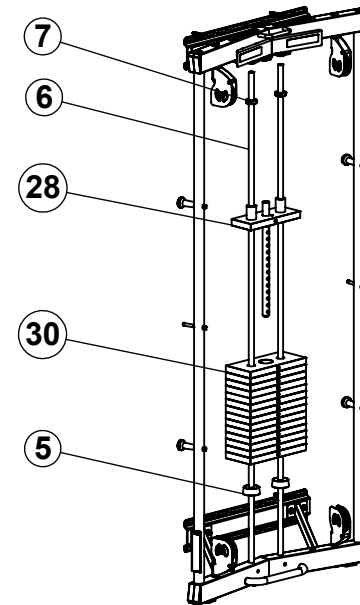

225 LB OPTION

## STEP 7

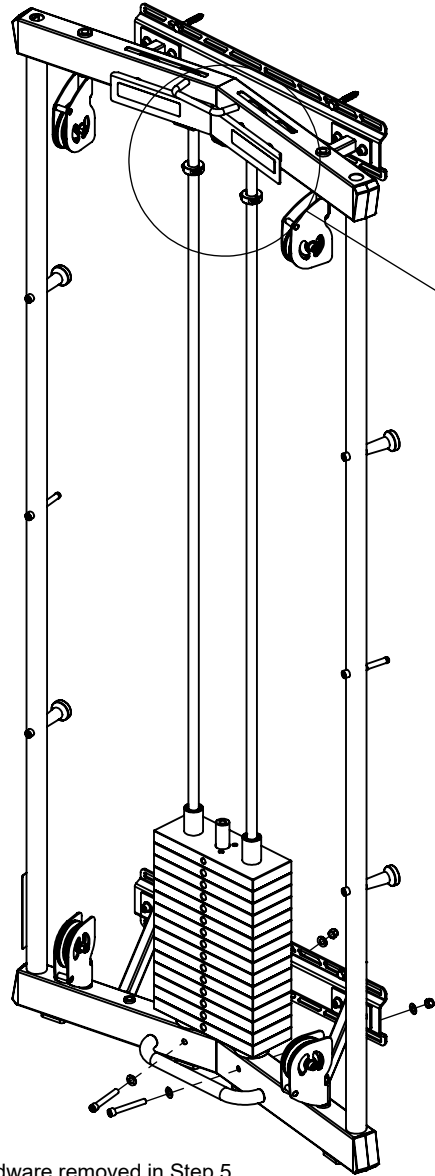

### **NOTE**

Install hardware removed in Step 5.  
Lift up on guide rods and insert bolts.  
Tighten until hardware doesn't move.  
**Do not** crush tube.

### **NOTE**

Push down the guide rods  
and slide collars to the top.  
**Securely tighten four  
screws**

**SECURELY** tighten all bolt connections in this step.

**STEP 7B**

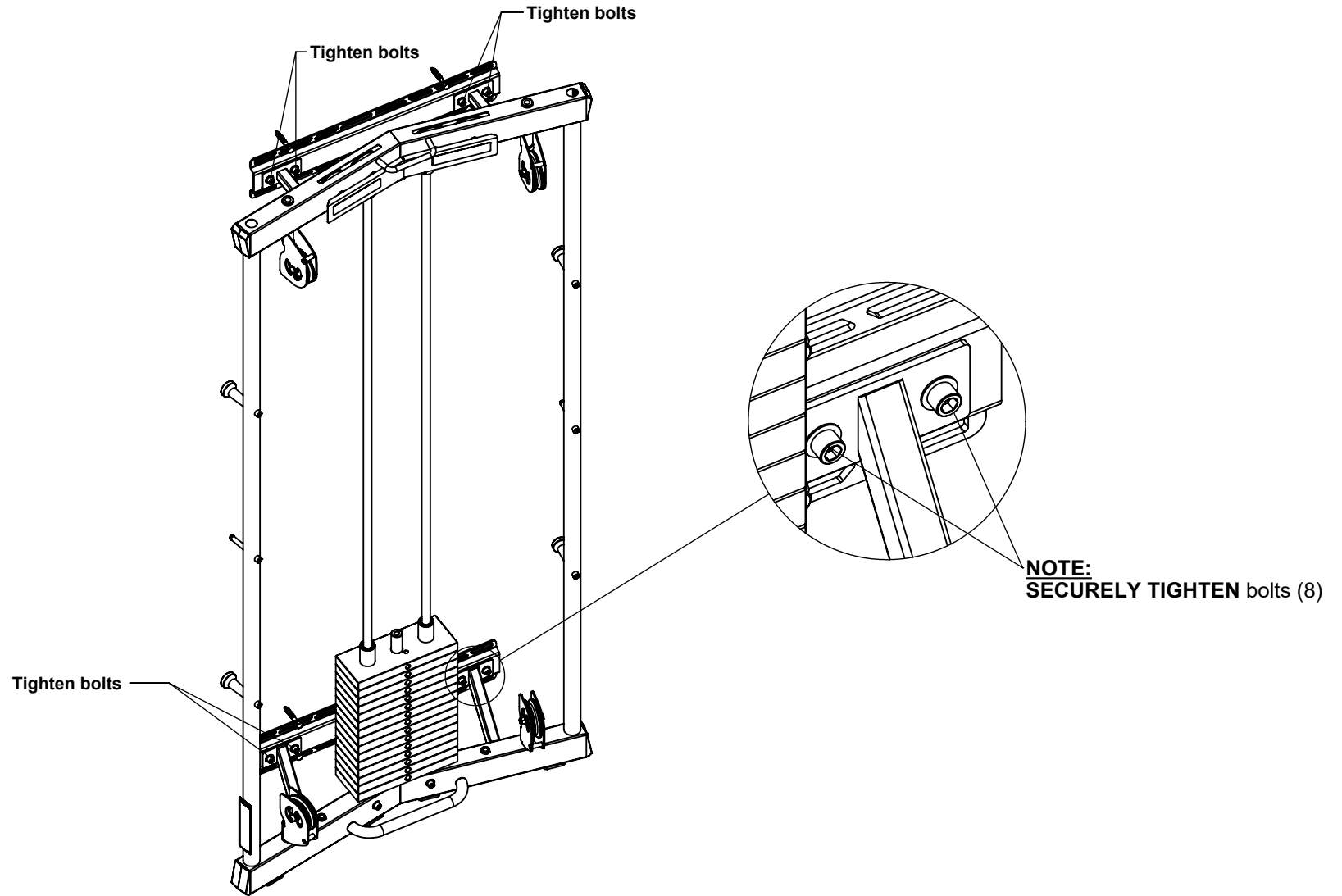

**SECURELY** tighten all bolt connections in this step and in previous steps.

# STEP 8

FRONT VIEW

**NOTE:**

Apply the weight stack labels to the right of the holes on weight plates by following the installation instructions printed on the label.

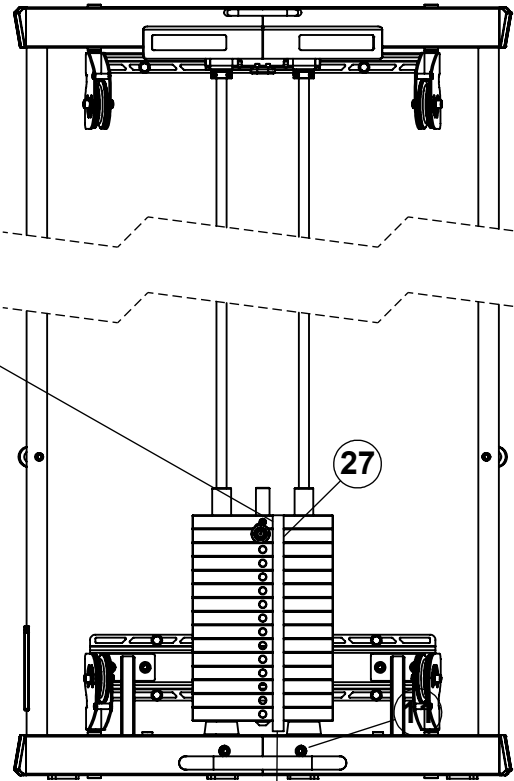

**NOTE:**

Discard labels 16-20

27

20

**NOTE:**

After weight stack labels have been applied, use a rubber mallet to carefully install insert plug of the weight stack pin into the center hole of the head plate.

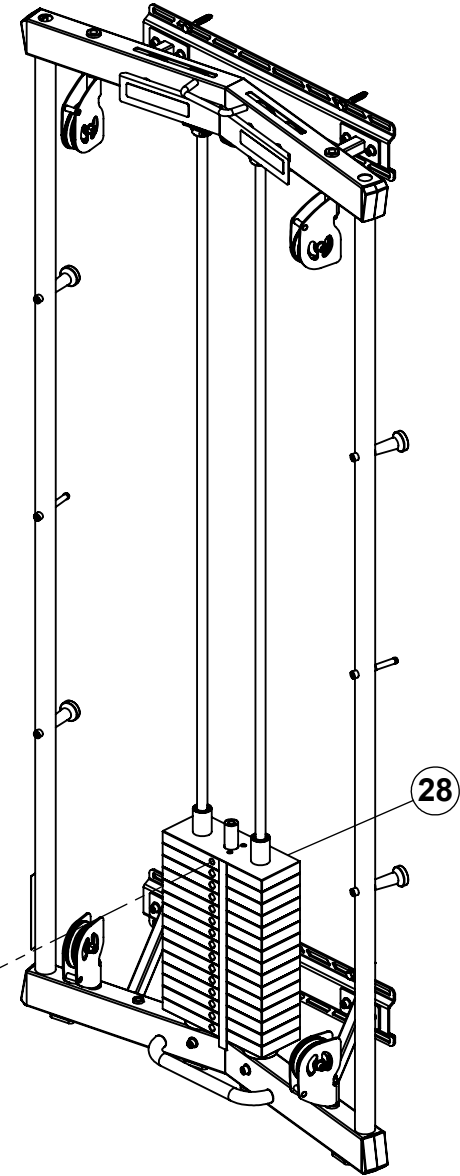

28

# STEP 9

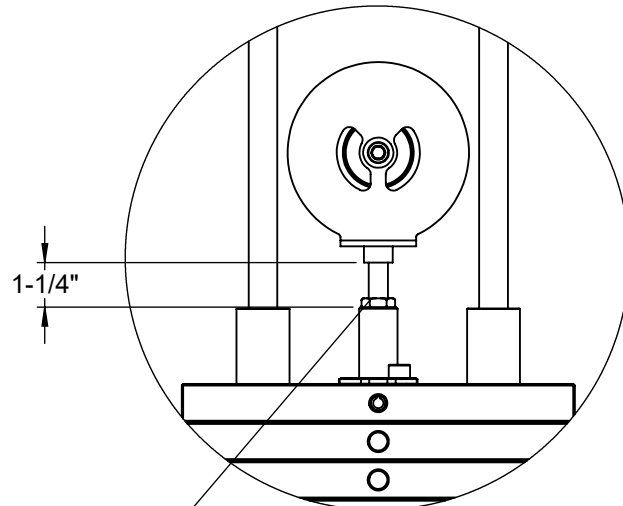

**NOTE:**  
**SECURELY** tighten jam nut.

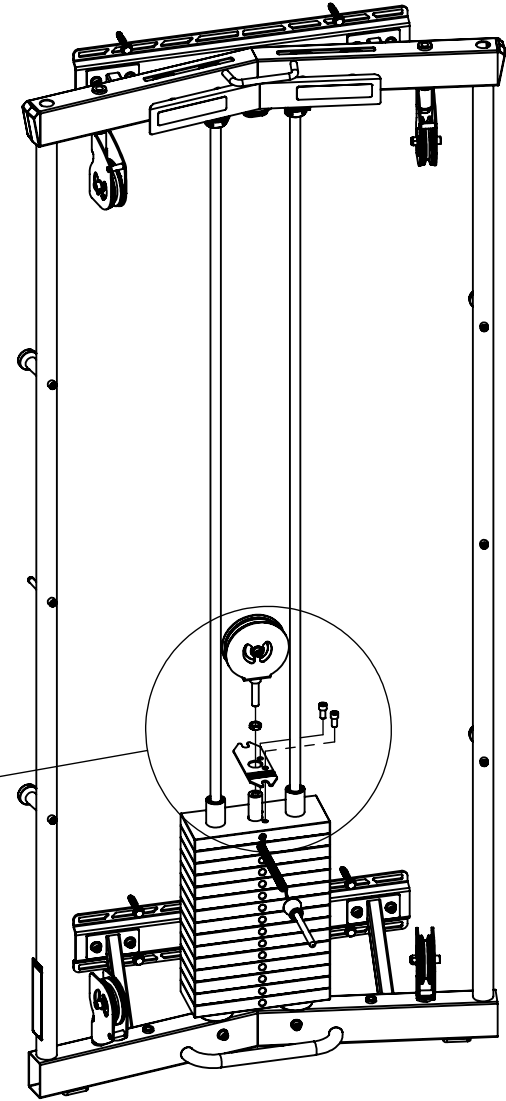
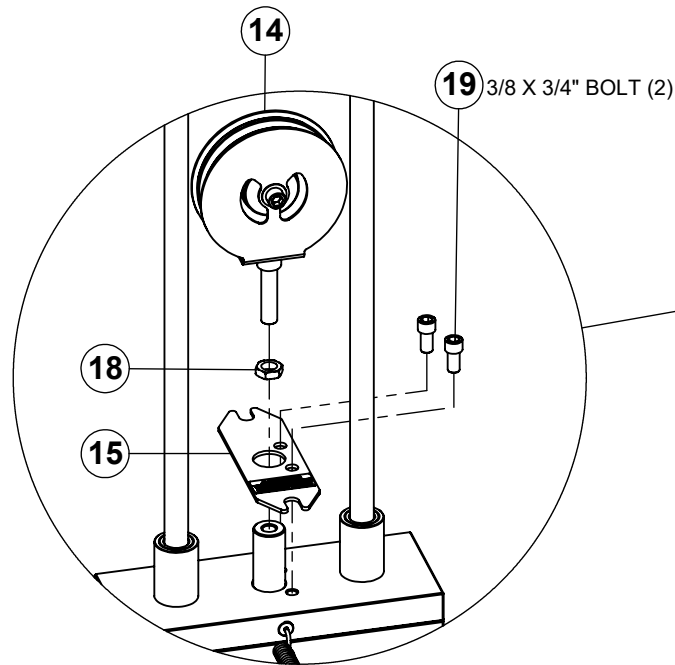

**SECURELY** tighten all bolt connections in this step.

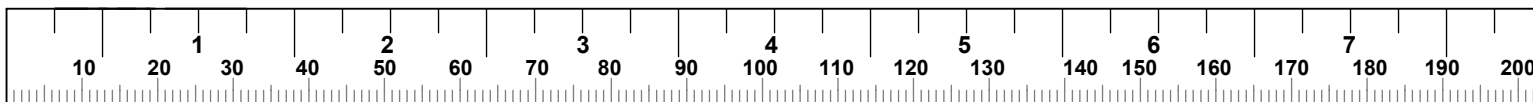

## STEP 10

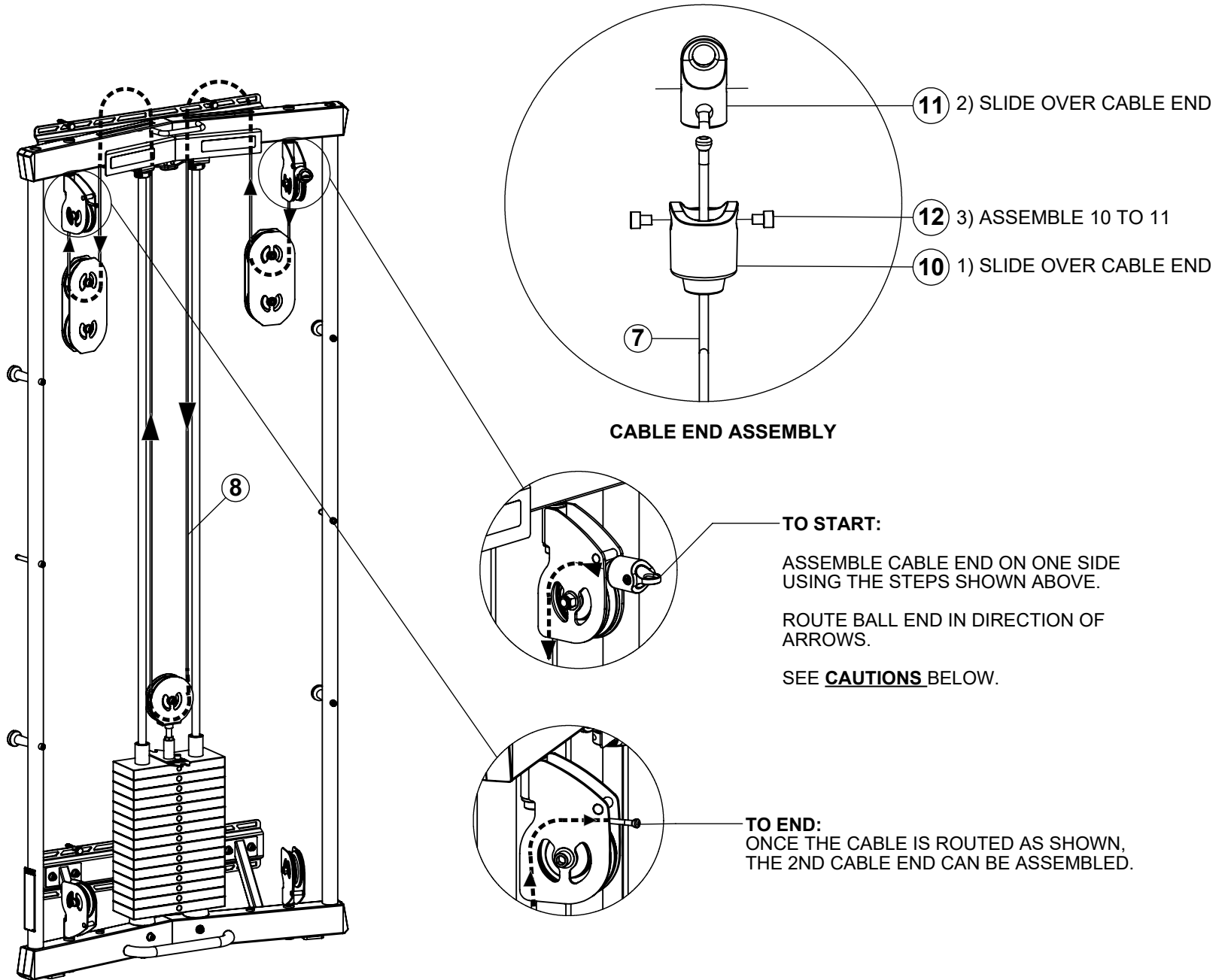

**SECURELY** tighten all bolt connections in this step.

**CAUTION:** When routing cables, make sure that the cables are seated in the groove of the pulleys and underneath all retaining bolts, pins or brackets. **Failure to do so, may result in damage to cable.**

## STEP 11

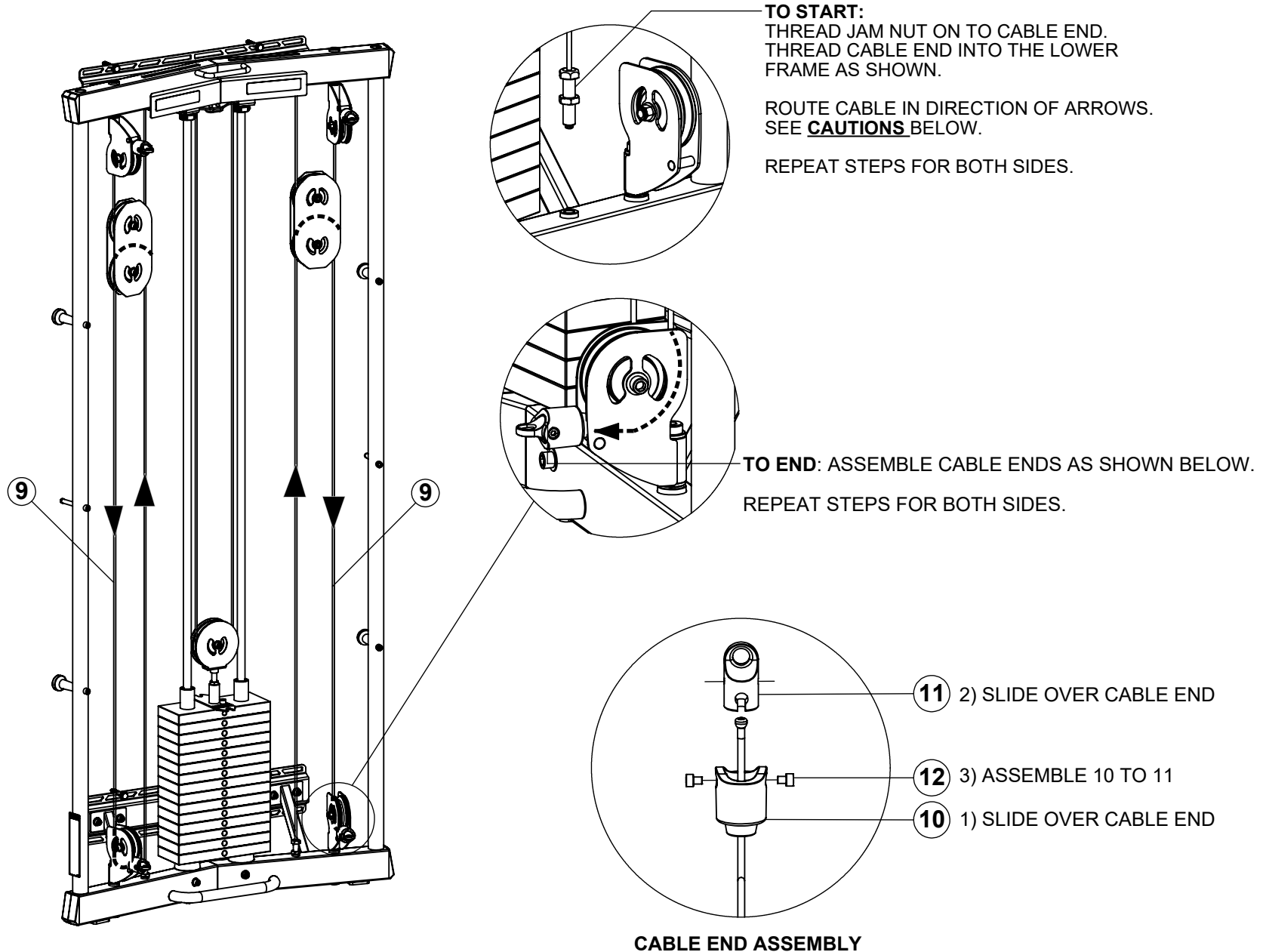

**SECURELY** tighten all bolt connections in this step.

**CAUTION:** When routing cables, make sure that the cables are seated in the groove of the pulleys and underneath all retaining bolts, pins or brackets. **Failure to do so, may result in damage to cable.**

## STEP 12

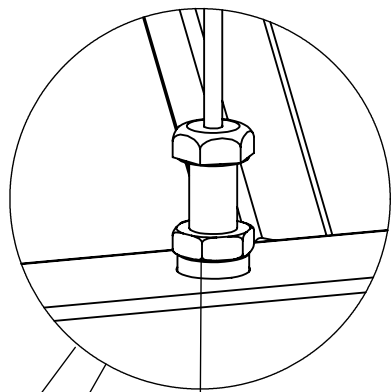
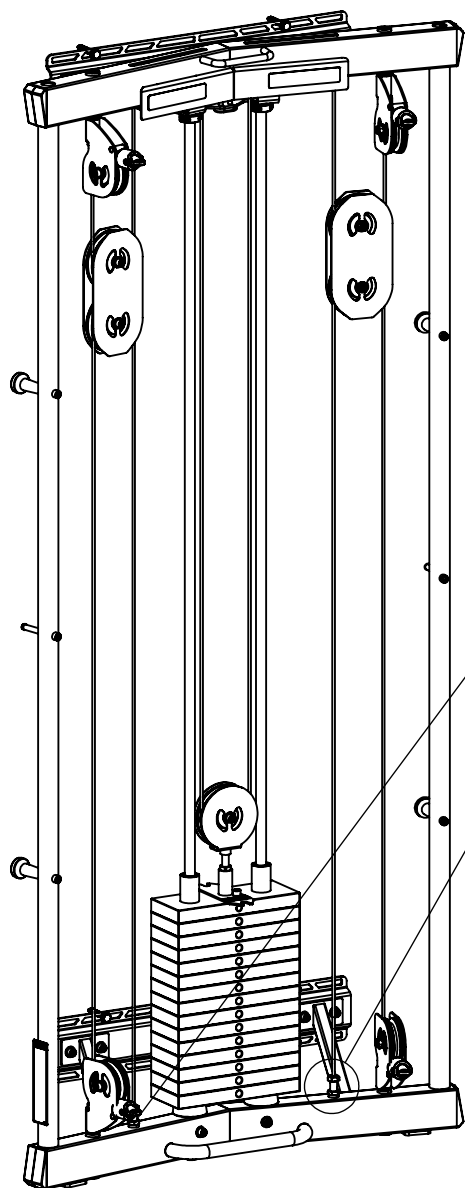

**NOTE:**

If there is a gap between the head plate and first plate, loosen jam nut and turn threaded end counter clockwise until the head plate touches the first plate.

**SECURELY** tighten jam nut.

To add tension to the cable, turn the threaded end clockwise.

**SECURELY** tighten jam nut.

Repeat steps for both cables if necessary.

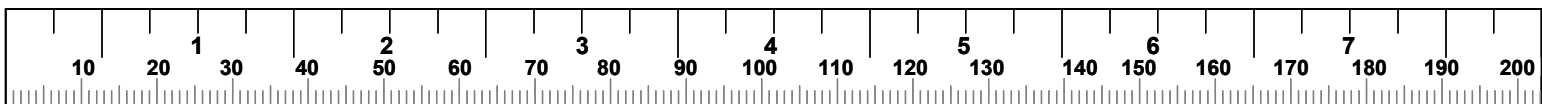

## STEP 13 (ACCESSORIES)

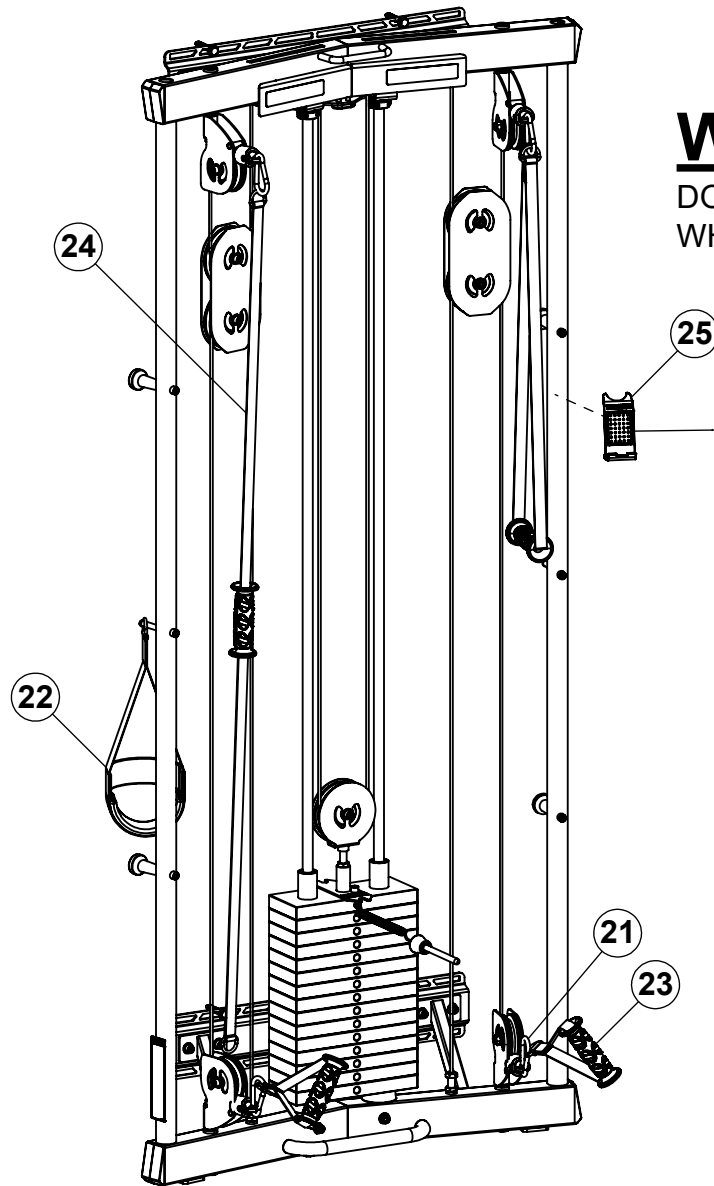

## **WARNING:**

DO NOT DROP WEIGHT STACK  
WHEN USING PHONE HOLDER

### **NOTE:**

Magnetic phone holder attachment can  
be positioned and adjusted to desired  
height and position.

## STEP 14 (OPTIONAL PULL UP ATTACHMENT)

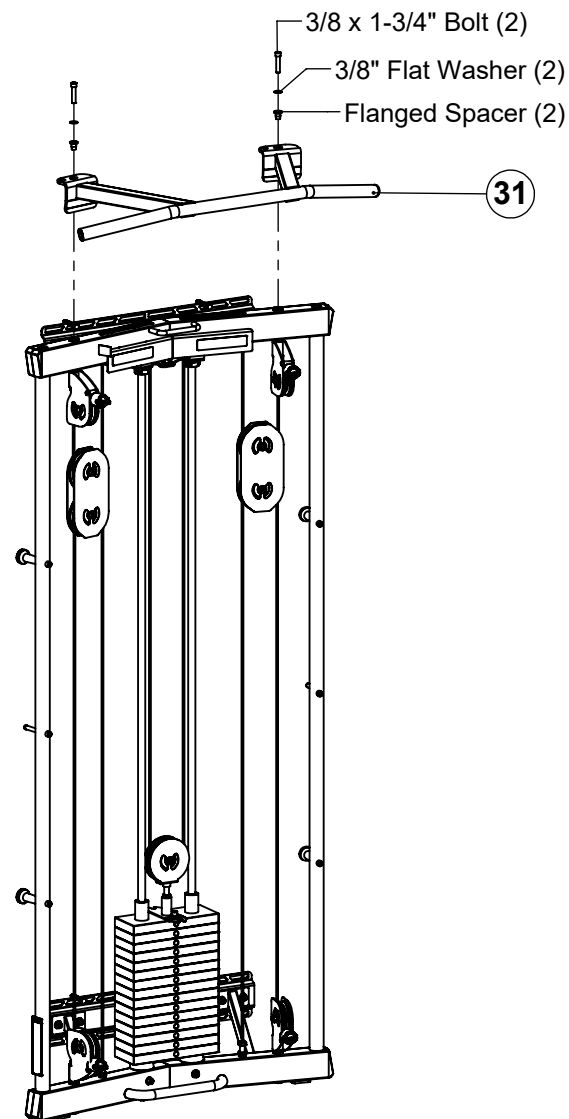

**NOTE:** Mounting hardware is included with the attachment being assembled.

**SECURELY** tighten all bolt connections in this step.

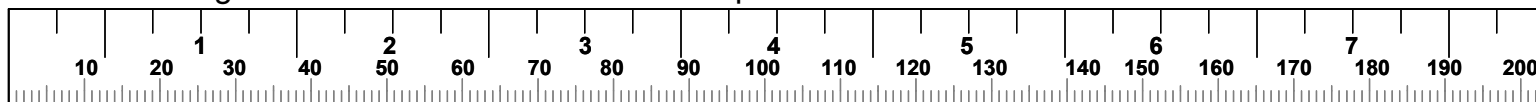

## STEP 15

### MAINTENANCE:

**GUIDE RODS:** Clean and lubricate with a silicone or teflon base lubricant.

**NUTS/BOLTS:** Tighten and/or adjust as needed.

**CABLES:** Check tension, end fittings, and coating. Replace if damaged or worn. Check jam nuts on cable ends. (NOTICE: NEW CABLES ALWAYS STRETCH DURING USE. REFER TO STEP 12 FOR ADJUSTING CABLE TENSION)

**FRAME:** Wipe down with damp cloth.

**GRIPS:** Inspect and replace if they appear worn or damaged.

For customer service contact Torque Fitness Customer service at: 763-754-7533 (8:30 am - 5:00 pm CST).  
Email: [service@torquefitness.com](mailto:service@torquefitness.com)

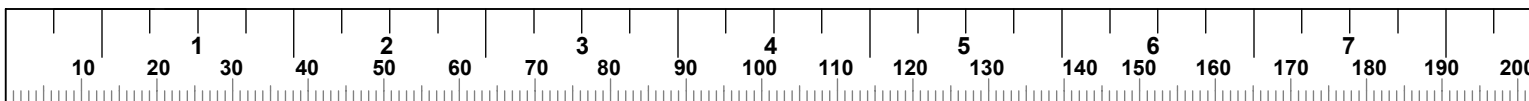
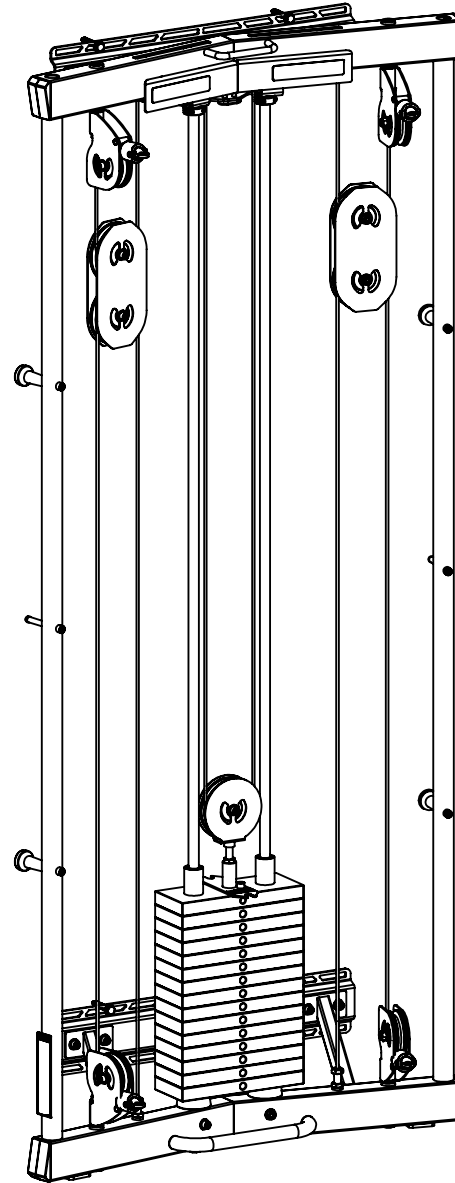

## WARNING

SERIOUS INJURY CAN OCCUR ON THIS EQUIPMENT. YOU MUST FOLLOW THESE PRECAUTIONS TO AVOID INJURY!

1. Before using, read all warnings and obtain instruction on the use of this machine. Use only for intended exercise. **DO NOT** modify the machine.
2. Obtain a medical exam before beginning any exercise program.
3. Keep body, hair and clothing free of all moving objects.
4. Inspect the machines before use. **DO NOT** use if it appears damaged. **DO NOT** attempt to fix a broken or jammed machine. Notify staff immediately.
5. Be certain that weight pin is completely inserted. Use only the pin provided by the manufacturer. If unsure, seek assistance.
6. Never pin the weights or prop plate into an elevated position. **DO NOT** use the machine if found in this condition. **DO NOT** attempt to fix. Seek assistance.
7. Inspect cables and their connections before using machine. **DO NOT** attempt to fix. Seek assistance.
8. Use only the incremental weights supplied by the manufacture. **DO NOT** use dumbbells or other means to add resistance to the machine.
9. Children must not be allowed near this machine. Supervise teenagers.
10. **DO NOT REMOVE THIS LABEL. REPLACE IF DAMAGED.**

P/N 5342301

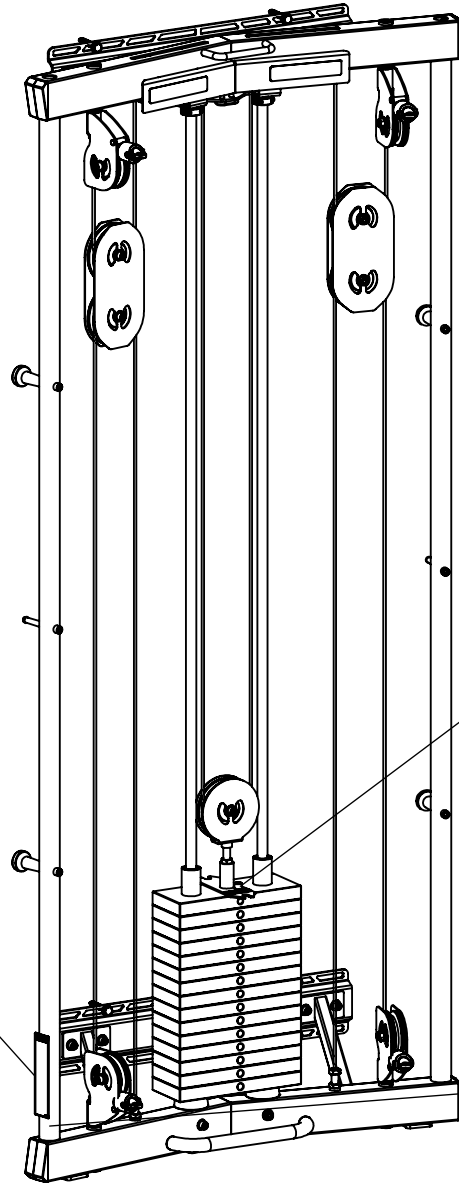

## WARNING

**WEIGHT STACK SELECTOR  
MUST BE FULLY ENGAGED**

**TORQUE<sup>USA</sup>**

Model:

S/N:



MADE IN CHINA

**TORQUE FITNESS**

11201 Xeon St NW Ste 101  
Coon Rapids, MN 55448

**LIVE AREA**

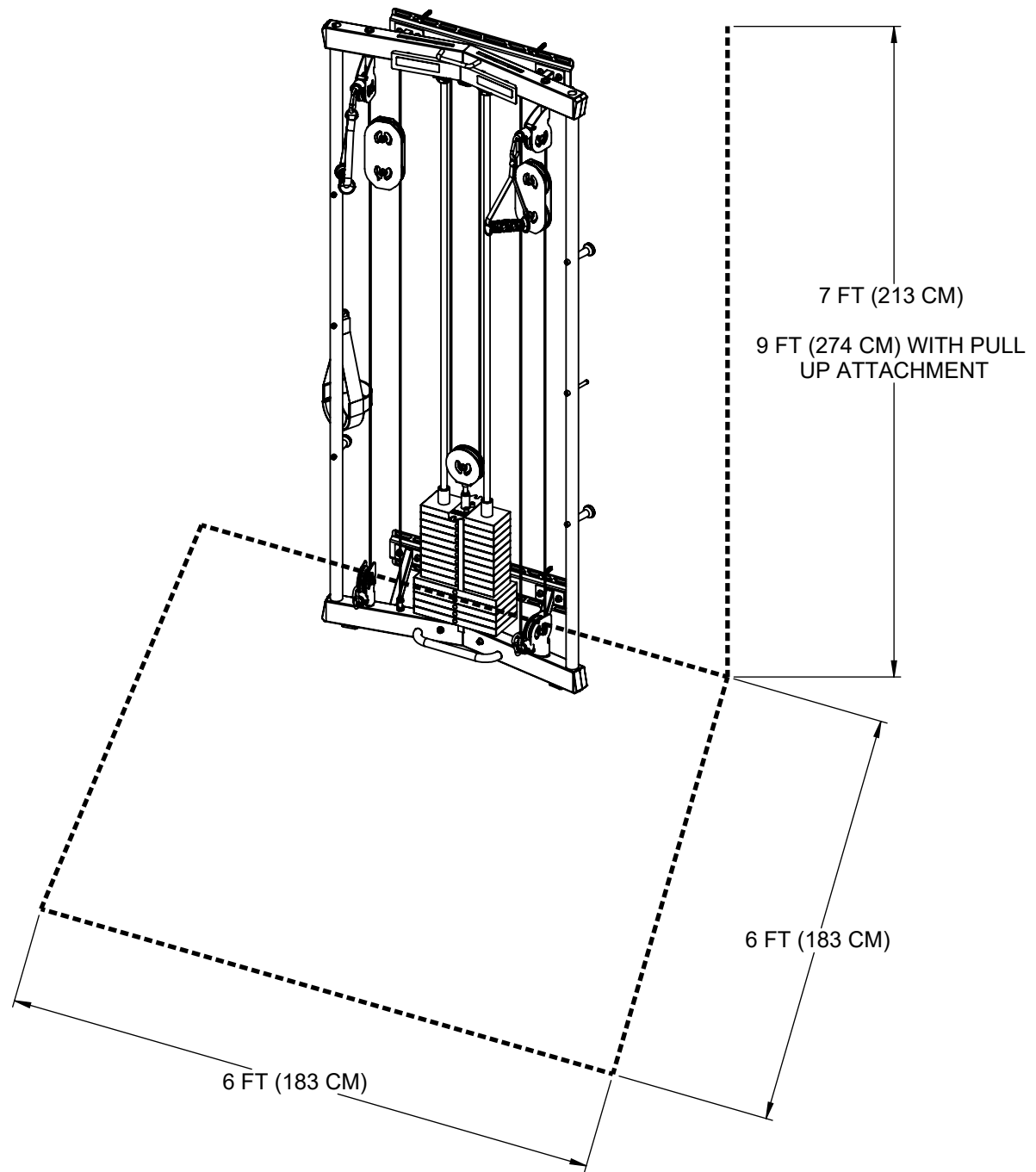

## ***DIMENSIONS***

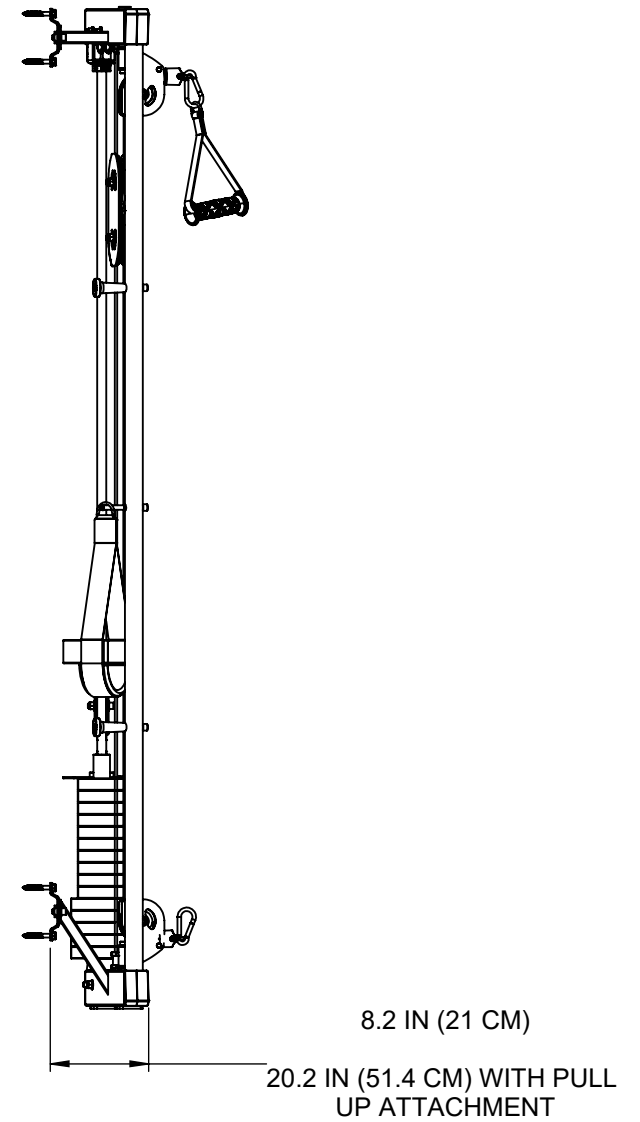
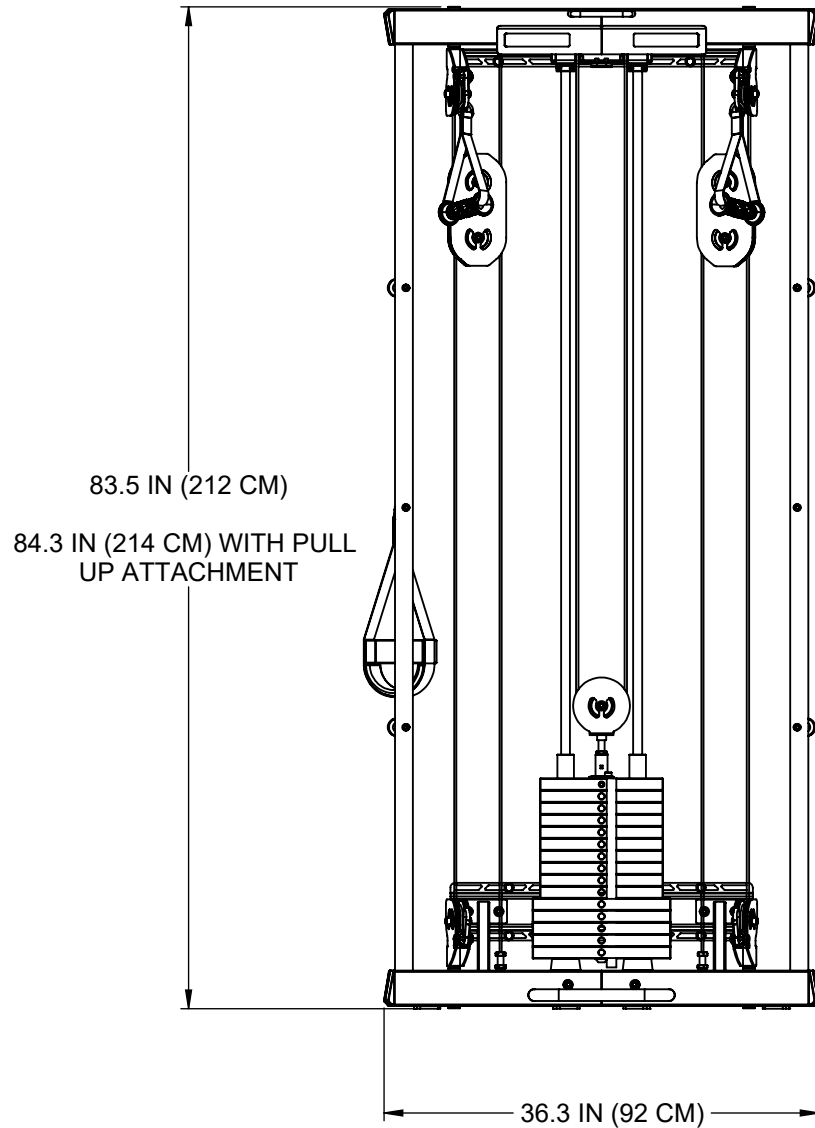

**ANKER 3 BASE UNIT WEIGHT : 85 LBS (38.5 KG)**

TO CALCULATE TOTAL WEIGHT ADD DESIRED WEIGHT STACK TO BASE UNIT WEIGHT.

**Exercise Instructions**

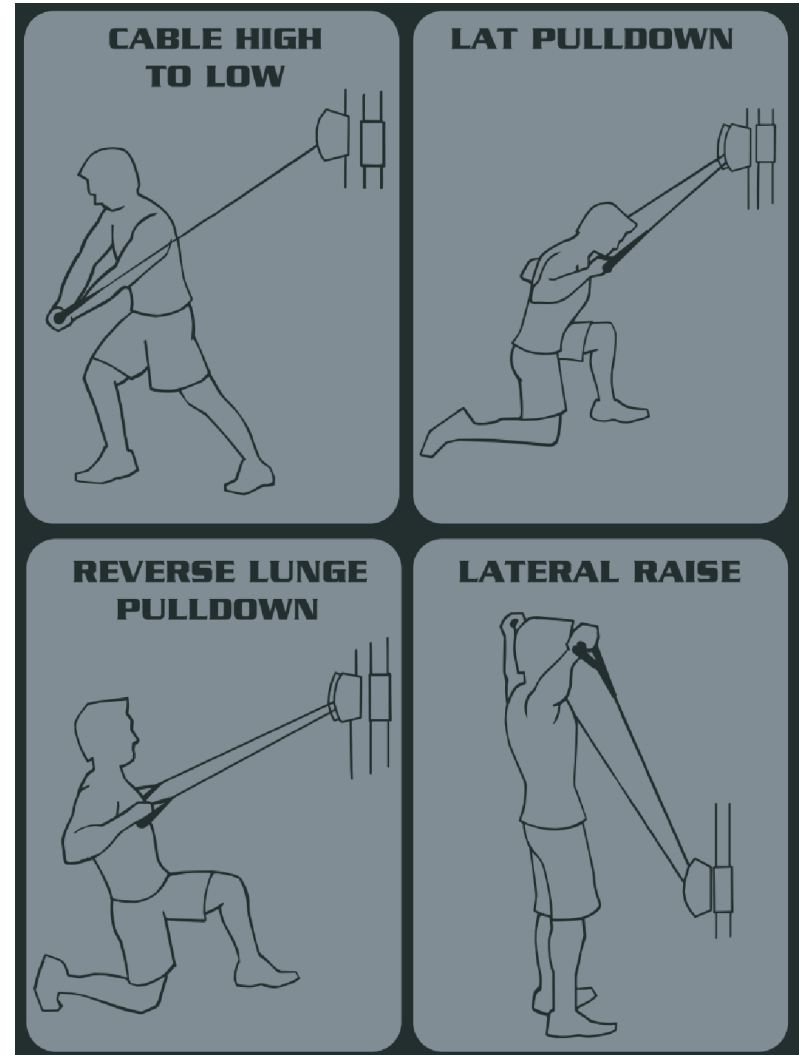
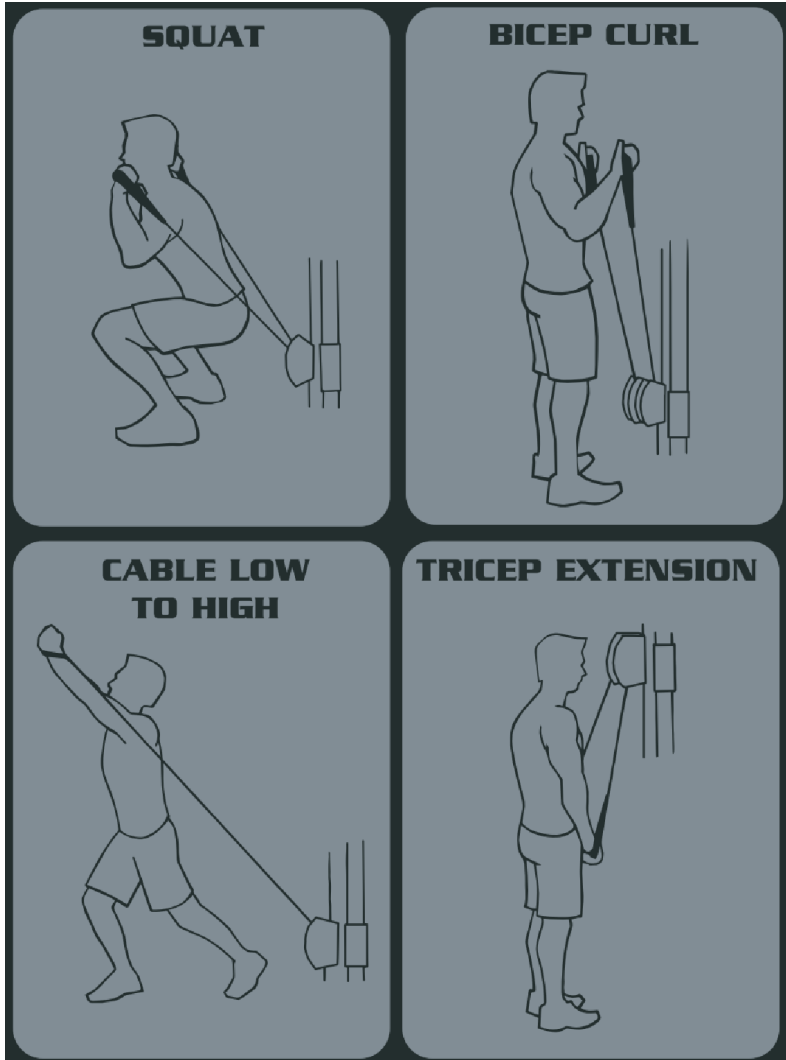

## ANKER 3 STRENGTH TRAINER - RESISTANCE RATIO CHART

### ANKER-3-003-150LB

NUMBER	ACTUAL WEIGHT (LB)	ACTUAL WEIGHT (KG)	SINGLE HANDLE (LB)	BOTH HANDLES (LB)	SINGLE HANDLE (KG)	BOTH HANDLES (KG)
1	15	6.8	7.5	15.0	3.4	6.8
2	25	11.3	12.5	25.0	5.7	11.3
3	35	15.9	17.5	35.0	7.9	15.9
4	45	20.4	22.5	45.0	10.2	20.4
5	55	24.9	27.5	55.0	12.5	24.9
6	65	29.5	32.5	65.0	14.7	29.5
7	75	34.0	37.5	75.0	17.0	34.0
8	85	38.6	42.5	85.0	19.3	38.6
9	95	43.1	47.5	95.0	21.5	43.1
10	105	47.6	52.5	105.0	23.8	47.6
11	115	52.2	57.5	115.0	26.1	52.2
12	125	56.7	62.5	125.0	28.3	56.7
13	135	61.2	67.5	135.0	30.6	61.2
14	145	65.8	72.5	145.0	32.9	65.8
15	155	70.3	77.5	155.0	35.2	70.3

### ANKER-3-003-200LB

NUMBER	ACTUAL WEIGHT (LB)	ACTUAL WEIGHT (KG)	SINGLE HANDLE (LB)	BOTH HANDLES (LB)	SINGLE HANDLE (KG)	BOTH HANDLES (KG)
1	15	6.8	7.5	15.0	3.4	6.8
2	25	11.3	12.5	25.0	5.7	11.3
3	35	15.9	17.5	35.0	7.9	15.9
4	45	20.4	22.5	45.0	10.2	20.4
5	55	24.9	27.5	55.0	12.5	24.9
6	70	31.8	35.0	70.0	15.9	31.8
7	85	38.6	42.5	85.0	19.3	38.6
8	100	45.4	50.0	100.0	22.7	45.4
9	115	52.2	57.5	115.0	26.1	52.2
10	130	59.0	65.0	130.0	29.5	59.0
11	145	65.8	72.5	145.0	32.9	65.8
12	160	72.6	80.0	160.0	36.3	72.6
13	175	79.4	87.5	175.0	39.7	79.4
14	190	86.2	95.0	190.0	43.1	86.2
15	205	93.0	102.5	205.0	46.5	93.0

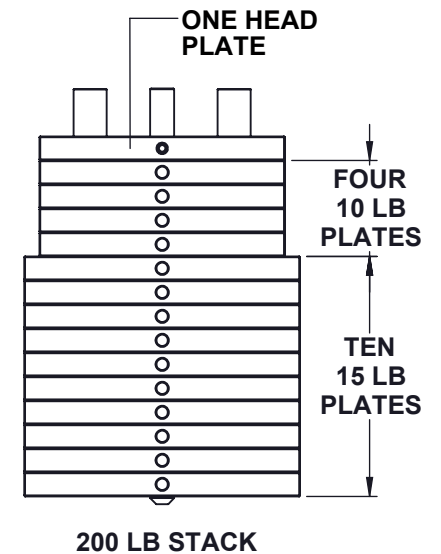
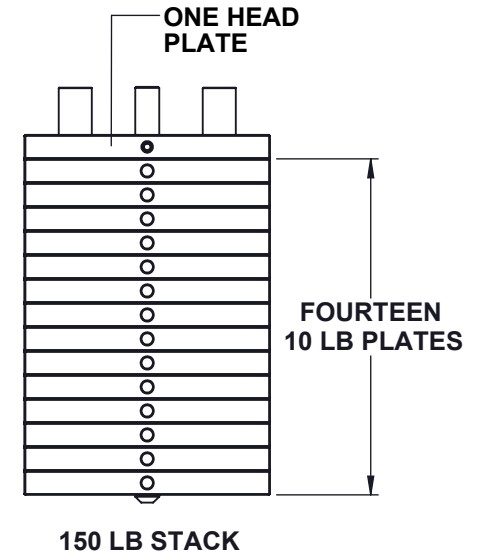

## ANKER 3 STRENGTH TRAINER - RESISTANCE RATIO CHART

ANKER-3-003-225LB

NUMBER	ACTUAL WEIGHT (LB)	ACTUAL WEIGHT (KG)	SINGLE HANDLE (LB)	BOTH HANDLES (LB)	SINGLE HANDLE (KG)	BOTH HANDLES (KG)
1	15	6.8	7.5	15.0	3.4	6.8
2	30	13.6	15.0	30.0	6.8	13.6
3	45	20.4	22.5	45.0	10.2	20.4
4	60	27.2	30.0	60.0	13.6	27.2
5	75	34.0	37.5	75.0	17.0	34.0
6	90	40.8	45.0	90.0	20.4	40.8
7	105	47.6	52.5	105.0	23.8	47.6
8	120	54.4	60.0	120.0	27.2	54.4
9	135	61.2	67.5	135.0	30.6	61.2
10	150	68.0	75.0	150.0	34.0	68.0
11	165	74.8	82.5	165.0	37.4	74.8
12	180	81.6	90.0	180.0	40.8	81.6
13	195	88.5	97.5	195.0	44.2	88.5
14	210	95.3	105.0	210.0	47.6	95.3
15	225	102.1	112.5	225.0	51.0	102.1

